

Head Office : A-1/28, Ground Floor, Janakpuri, New Delhi : 9310464558 / 9354664558

TEST BOOKLET NO.108

TEST BOOKLET CODE

ROLL NUMBER

--	--	--	--	--	--	--	--	--	--

**Test Series - NEET**

**TEST -08**

**NEET(UG)-2026**

**T-08**

Do not open this Test Booklet until you are asked to do so.

**Syllabus**

**Physics:** EM Wave, Optics

**Chemistry :** Aldehyde & Ketones, Acid & Derivatives, Nitrogen Containing Compounds

**Biology :** Microbes in Human Welfare, Organisms and Population, Human Health and Disease

**Important Instructions :**

1. This test is of **3 Hours** duration.
2. The Test Booklet contains **180** multiple-choice questions [four options (1), (2), (3) & (4) with a single correct answer] from **Physics (45 Questions), Chemistry (45 Questions) & Biology (90 Questions)**.  
**All questions are compulsory.**
3. Each question carries **4** marks. For each correct response, the candidate will get **4** marks. For each incorrect response, **1** mark will be deducted from the total score. No mark will be deducted for the questions which have not been answered. The maximum marks is **720**.
4. Use **Blue/Black Ball Point Pen only** for writing particulars on this page/special Answer Sheet (OMR).
5. Do not encode or darken more than one circle for answering a particular question for it will be treated as a wrong answer.
6. Rough work is to be done on the space provided for this purpose in the Test Booklet only.
7. Calculators, Slide Rules, Log Tables, Geometry Box, Electronic Digital Watches with facilities of calculators, cellular phones, pagers or any other electronic gadget are not allowed inside the Examination Hall.

Name of the Candidate (in Capital) : \_\_\_\_\_

Centre Name (in Capital) : \_\_\_\_\_ Date : \_\_\_\_\_

Candidate's Signature : \_\_\_\_\_ Invigilator's Signature : \_\_\_\_\_

1. When an object is placed 40 cm away from a spherical mirror an image of magnification  $1/2$  is produced. To obtain an image with magnification of  $1/3$ , the object is to be moved:

[NCERT Page 225, 226]

- (1) 40 cm away from the mirror.
  - (2) 80 cm away from the mirror.
  - (3) 20 cm towards the mirror.
  - (4) 20 cm away from the mirror.
2. For the same angle of incidence  $i = 55^\circ$  in air, the angles of refraction in media 'P', 'Q', 'R' and 'S' are  $50^\circ, 40^\circ, 30^\circ, 20^\circ$  respectively. The speed of light is minimum in medium

[NCERT Page 228]

- (1) P
  - (2) Q
  - (3) R
  - (4) S
3. Figure shows wavefront P passing through two systems A and B and emerging as Q and then as R. The system A and B could, respectively, be

[NCERT Page 261]

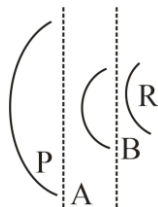

- (1) a prism and a convergent lens
  - (2) a convergent lens and a prism
  - (3) a divergent lens and a prism
  - (4) a convergent lens and a divergent lens
4. When light suffers reflection at the interface between water and glass, the change of phase in the reflected wave is

[NCERT Page 260, 261]

- (1) zero
  - (2)  $\pi$
  - (3)  $\pi/2$
  - (4)  $2\pi$
5. A spherical surface separates two media of refractive indices 1 and 1.5 as shown in figure. Distance of the image of an object 'O', is : (C is the centre of curvature of the spherical

surface and R is the radius of curvature)

[NCERT Page 233]

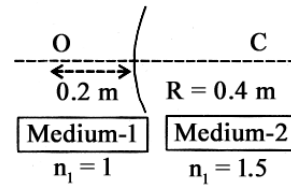

- (1) 0.24 m right to the spherical surface
  - (2) 0.4 m left to the spherical surface
  - (3) 0.24 m left to the spherical surface
  - (4) 0.4 m right to the spherical surface
6. The electric field in an electromagnetic wave is given as  $\vec{E} = 20 \sin \omega \left( t - \frac{x}{c} \right) \hat{j} \text{ NC}^{-1}$ . Where  $\omega$  and  $c$  are angular frequency and velocity of electromagnetic wave respectively. The energy contained in a volume of  $5 \times 10^{-4} \text{ m}^3$  will be (Given :  $\epsilon_0 = 8.85 \times 10^{-12} \text{ C}^2/\text{Nm}^2$ )
- (1)  $28.5 \times 10^{-13} \text{ J}$
  - (2)  $17.7 \times 10^{-13} \text{ J}$
  - (3)  $8.85 \times 10^{-13} \text{ J}$
  - (4)  $88.5 \times 10^{-13} \text{ J}$
7. A light wave is propagating with plane wave fronts of the type  $x + y + z = \text{constant}$ . The angle made by the direction of wave propagation with x-axis is

[NCERT Page 257, 258]

- (1)  $\cos^{-1} \left( \frac{1}{\sqrt{3}} \right)$
  - (2)  $\cos^{-1} \left( \frac{2}{3} \right)$
  - (3)  $\cos^{-1} \left( \frac{1}{3} \right)$
  - (4)  $\cos^{-1} \left( \sqrt{\frac{2}{3}} \right)$
8. The graph between angle of deviation ( $\delta$ ) and angle of incidence ( $i$ ) for a triangular prism is represented by

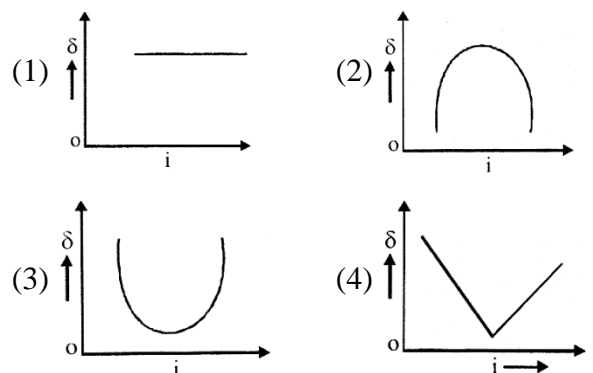

9. A narrow, paraxial beam of light is converging towards a point I on a screen. A plane parallel plate of glass of thickness  $t$ , and refractive index  $\mu$  is introduced in the path of the beam. The convergence point is shifted by

- (1)  $t(1 - 1/\mu)$  away
- (2)  $t(1 + 1/\mu)$  away
- (3)  $t(1 - 1/\mu)$  nearer
- (4)  $t(1 + 1/\mu)$  nearer

10. In a Young's double slit experiment, the slits are separated by 0.2 mm. If the slits separation is increased to 0.4 mm, the percentage change of the fringe width is:

[NCERT Page 265, 266]

- (1) 0%
- (2) 100%
- (3) 50%
- (4) 25%

11. A microscope is focused on a coin lying at the bottom of a beaker. The microscope is now raised by 1 cm. To what depth should water be poured into the beaker so that the coin is again in focus? (The refractive index of water is  $4/3$ )

- (1) 1 cm
- (2)  $4/3$  cm
- (3) 3 cm
- (4) 4 cm

12. Microwaves are electromagnetic waves with frequency in the range of

[NCERT Page 209]

- (1) Micro hertz
- (2) Giga hertz
- (3) Mega hertz
- (4) Hertz

13. A transparent block A having refractive index  $\mu = 1.25$  is surrounded by another medium of refractive index  $\mu = 1.0$  as shown in figure. A light ray is incident on the flat face of the block with incident angle  $\theta$  as shown in figure. What is the maximum value of  $\theta$  for which light suffers total internal reflection at the top surface of the block?

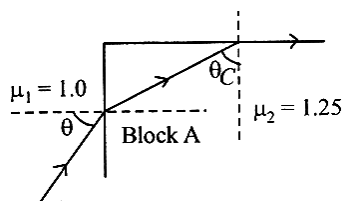

[NCERT Page 228, 230]

- (1)  $\tan^{-1}(4/3)$
- (2)  $\tan^{-1}(3/4)$
- (3)  $\sin^{-1}(3/4)$
- (4)  $\cos^{-1}(3/4)$

14. A monochromatic light is incident at a certain angle on an equilateral triangular prism and suffers minimum deviation. If the refractive index of the material of the prism is  $\sqrt{3}$ , then the angle of incidence is

- (1)  $90^\circ$
- (2)  $30^\circ$
- (3)  $60^\circ$
- (4)  $45^\circ$

15. The electric field of a plane electromagnetic wave propagating along the  $x$  direction in vacuum is  $\vec{E} = E_0 \hat{j} \cos(\omega t - kx)$ . The magnetic field  $\vec{B}$ , at the moment  $t = 0$  is

[NCERT Page 206, 207]

- (1)  $\vec{B} = \frac{E_0}{\sqrt{\mu_0 \epsilon_0}} \cos(kx) \hat{k}$
- (2)  $\vec{B} = E_0 \sqrt{\mu_0 \epsilon_0} \cos(kx) \hat{j}$
- (3)  $\vec{B} = E_0 \sqrt{\mu_0 \epsilon_0} \cos(kx) \hat{k}$
- (4)  $\vec{B} = \frac{E_0}{\sqrt{\mu_0 \epsilon_0}} \cos(kx) \hat{j}$

16. In Young's double slit experiment, light from two identical sources are superimposing on a screen. The path difference between the two lights reaching at a point on the screen is  $7\lambda/4$ . The ratio of intensity of fringe at this point with respect to the maximum intensity of the fringe is

[NCERT Page 265, 266]

- (1)  $1/4$
- (2)  $1/3$
- (3)  $3/4$
- (4)  $1/2$

17. To increase the angular magnification of a simple microscope, one should increase

[NCERT Page 242]

- (1) the focal length of the lens
- (2) the power of the lens
- (3) the aperture of the lens
- (4) the object size

18. The diameter of aperture of a plano-convex lens is 6 cm and its maximum thickness is 3 mm. If the velocity of light in the material of the lens is  $2 \times 10^8$  m/s, its focal length is

(approximately)

- (1) 10 cm (2) 15 cm  
(3) 30 cm (4) 60 cm

19. The magnetic field of a plane electromagnetic wave is  $\vec{B} = 3 \times 10^{-8} \sin[200\pi(y + ct)]\hat{T}$ , where  $c = 3 \times 10^8 \text{ ms}^{-1}$  is the speed of light. The corresponding electric field is

[NCERT Page 206, 207]

- (1)  $\vec{E} = 9 \sin[200\pi(y + ct)]\hat{k} \text{ V/m}$   
(2)  $\vec{E} = -10^{-6} \sin[200\pi(y + ct)]\hat{k} \text{ V/m}$   
(3)  $\vec{E} = 3 \times 10^{-8} \sin[200\pi(y + ct)]\hat{k} \text{ V/m}$   
(4)  $\vec{E} = -9 \sin[200\pi(y + ct)]\hat{k} \text{ V/m}$

20. A monochromatic light of frequency  $5 \times 10^{14}$  Hz travelling through air, is incident on a medium of refractive index '2'. Wavelength of the refracted light will be:

[NCERT Page 259, 260]

- (1) 300 nm (2) 600 nm  
(3) 400 nm (4) 500 nm

21. Light emerges out of a convex lens when a source of light kept at its focus. The shape of wavefront of the light is

[NCERT Page 261]

- (1) Both spherical and cylindrical  
(2) Cylindrical  
(3) Spherical  
(4) Plane

22. A planoconcave lens is placed on a paper on which a flower is drawn. How far above its actual position does the flower appear to be?

[NCERT Page 233]

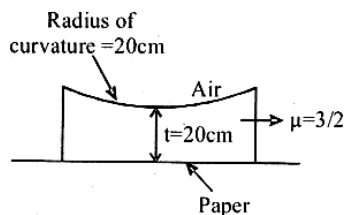

- (1) (2) 15 cm  
(3) 50 cm (4) None of these

23. A plane electromagnetic wave is incident on a plane surface of area A, normally and is perfectly reflected. If energy E strikes the surface in time t then average pressure exerted on the surface is (c = speed of light)

- (1) zero (2) E/Atc  
(3) 2E/Atc (4) E/c

24. A thin equiconvex glass lens of refractive index 1.5 has power of 5D. When the lens is immersed in a liquid of refractive index  $\mu$ , it acts as a divergent lens of focal length 100 cm. The value of  $\mu$  of liquid is

[NCERT Page 230]

- (1) 4/3 (2) 3/4  
(3) 5/3 (4) 8/3

25. If Young's double slit experiment is performed in water keeping the rest of the set-up same, the fringes will [NCERT Page 265, 266]

- (1) increase in width (2) decrease in width  
(3) remain unchanged (4) not be formed

26. Yellow light is refracted through a prism producing minimum deviation. If  $i_1$  and  $i_2$  denote the angle of incidence and emergence for the prism, then

- (1)  $i_1 = i_2$  (2)  $i_1 > i_2$   
(3)  $i_3 < i_2$  (4)  $i_1 + i_2 = 90$

27. A plane electromagnetic wave travels in a medium of relative permeability 1.61 and relative permittivity 6.44. If magnitude of magnetic intensity is  $4.5 \times 10^{-2} \text{ Am}^{-1}$  at a point, what will be the approximate magnitude of electric field intensity at point? (Given : permeability of free space  $\mu_0 = 4\pi \times 10^{-7} \text{ NA}^{-2}$ , speed of light in vacuum  $c = 3 \times 10^8 \text{ ms}^{-1}$ )

[NCERT Page 207]

- (1)  $16.96 \text{ Vm}^{-1}$  (2)  $2.25 \cdot 10^{-2} \text{ Vm}^{-1}$   
(3)  $4.2 \times 10^6 \text{ V/m}$  (4)  $6.75 \times 10^6 \text{ V/m}^{-1}$

28. A light ray falls on a rectangular glass slab as shown. The index of refraction of the glass, if total internal reflection is to occur at the vertical face, is

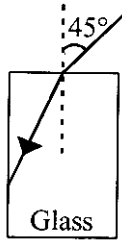

[NCERT Page 230]

- (1)  $\sqrt{3/2}$  (2)  $\frac{(\sqrt{3}+1)}{2}$   
 (3)  $\frac{(\sqrt{2}+1)}{2}$  (4)  $\sqrt{5}/2$

29. Two monochromatic light beams have intensities in the ratio 1:9. An interference pattern is obtained by these beams. The ratio of the intensities of maximum to minimum is

- (1) 8 : 1 (2) 9 : 1  
 (3) 3 : 1 (4) 4 : 1

30. A concave mirror produces an image of an object such that the distance between the object and image is 20 cm. If the magnification of the image is '-3', then the magnitude of the radius of curvature of the mirror is

[NCERT Page 225, 226]

- (1) 3.75 cm (2) 30 cm  
 (3) 7.5 cm (4) 15 cm

31. An EM wave propagating in x-direction has a wavelength of 8 mm. The electric field vibrating y-direction has maximum magnitude of  $60 \text{ Vm}^{-1}$ . Choose the correct equations for electric and magnetic fields if the EM wave is propagating in vacuum

[NCERT Page 206, 207]

- (1)  $E_y = 60 \sin \left[ \frac{\pi}{4} \times 10^3 (x - 3 \times 10^8 t) \right] \hat{j} \text{Vm}^{-1}$   
 $B_z = 2 \sin \left[ \frac{\pi}{4} \times 10^3 (x - 3 \times 10^8 t) \right] \hat{k} \text{T}$   
 (2)  $E_y = 60 \sin \left[ \frac{\pi}{4} \times 10^3 (x - 3 \times 10^8 t) \right] \hat{j} \text{Vm}^{-1}$   
 $B_z = 2 \times 10^{-7} \sin \left[ \frac{\pi}{4} \times 10^3 (x - 3 \times 10^8 t) \right] \hat{k} \text{T}$   
 (3)  $E_y = 2 \times 10^{-7} \sin \left[ \frac{\pi}{4} \times 10^3 (x - 3 \times 10^8 t) \right] \hat{j} \text{Vm}^{-1}$   
 $B_z = 60 \sin \left[ \frac{\pi}{4} \times 10^3 (x - 3 \times 10^8 t) \right] \hat{k} \text{T}$   
 (4)  $E_y = 2 \times 10^{-7} \sin \left[ \frac{\pi}{4} \times 10^3 (x - 4 \times 10^8 t) \right] \hat{j} \text{Vm}^{-1}$

$$B_z = 60 \sin \left[ \frac{\pi}{4} \times 10^4 (x - 4 \times 10^8 t) \right] \hat{k} \text{T}$$

32. Consider a Young's double slit experiment as shown in figure. What should be the slit separation  $d$  in terms of wavelength  $\lambda$  such that the first minima occurs directly in front of the slit ( $S_1$ )?

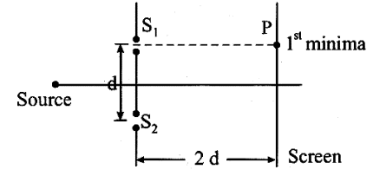

[NCERT Page 265, 266]

- (1)  $\frac{\lambda}{2(\sqrt{5}-2)}$  (2)  $\frac{\lambda}{(\sqrt{5}-2)}$   
 (3)  $\frac{\lambda}{2(5-\sqrt{2})}$  (4)  $\frac{\lambda}{(5-\sqrt{2})}$

33. A plane electromagnetic wave of frequency 20 MHz travels in free space along the +x direction. At a particular point in space and time, the electric field vector of the wave is  $E_y = 9.3 \text{ Vm}^{-1}$ . Then, the magnetic field vector of the point is

[NCERT Page 207]

- (1)  $B_z = 9.3 \times 10^{-8} \text{ T}$  (2)  $B_z = 1.55 \times 10^{-8} \text{ T}$   
 (3)  $B_z = 6.2 \times 10^{-8} \text{ T}$  (4)  $B_z = 3.1 \times 10^{-8} \text{ T}$

34. An unpolarized light beam of intensity  $2I_0$ , is passed through a polaroid P and then through another polaroid Q which is oriented in such a way that its passing axis makes an angle of  $30^\circ$  relative to that of P. The intensity of the emergent light is

[NCERT Page 270]

- (1)  $\frac{I_0}{4}$  (2)  $\frac{I_0}{2}$   
 (3)  $\frac{3I_0}{4}$  (4)  $\frac{3I_0}{2}$

35. A concave mirror of focal length  $f$  in air is dipped in a liquid of refractive index  $\mu$ . Its focal length in the liquid will be

- (1)  $\frac{f}{\mu}$  (2)  $\frac{f}{(\mu-1)}$   
 (3)  $\mu f$  (4)  $f$

36. A ray of light is incident at an angle of  $60^\circ$  on one face of a prism of angle  $30^\circ$ . The emergent ray of light makes an angle of  $30^\circ$  with incident ray. The angle made by the emergent ray with second face of prism will be

[NCERT Page 239, 240]

- (1)  $30^\circ$                       (2)  $90^\circ$   
 (3)  $0^\circ$                         (4)  $45^\circ$

37. Two plano-convex lenses of equal focal lengths are arranged as shown. The ratio of the combined focal length is

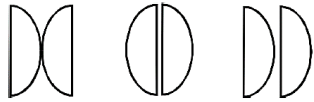

- (1) 1 : 2 : 1                      (2) 1 : 2 : 3  
 (3) 1 : 1 : 1                      (4) 2 : 1 : 2

38. The energy of an electromagnetic wave contained in a small volume oscillates with

- (1) zero frequency  
 (2) half the frequency of the wave  
 (3) double the frequency of the wave  
 (4) the frequency of the wave

39. The ratio of intensities at two points P and Q on the screen in a Young's double slit experiment where phase difference between two wave of same amplitude are  $\pi/3$  and  $\pi/2$ , respectively are

[NCERT Page 264, 265, 266]

- (1) 1 : 3                            (2) 3 : 1  
 (3) 3 : 2                            (4) 2 : 3

40. A plot between the angle of deviation and angle of incidence is shown in figure. From the graph one can say that the prism angle is

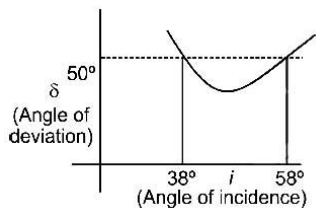

- (1)  $47^\circ$                             (2)  $46^\circ$   
 (3)  $45^\circ$                             (4)  $60^\circ$

41. In the diagram, a ray is passing through a broken prism, find angular deviation for the ray

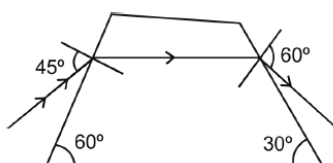

- (1)  $105^\circ$                         (2)  $30^\circ$   
 (3)  $60^\circ$                         (4)  $15^\circ$

42. The final image formed by an astronomical telescope is [NCERT Page 245]

- (1) real, erect and diminished  
 (2) virtual, inverted and diminished  
 (3) real, inverted and magnified  
 (4) virtual, inverted and magnified

43. Huygen's concept of secondary wave

[NCERT Page 257, 258]

- (1) allows us to find the focal length of a thick lens  
 (2) is a geometrical method to find a wavefront  
 (3) is used to determine the velocity of light  
 (4) is used to explain polarization

44. A lens is made up of 3 different transparent media as shown in figure. A point object O is placed on its axis beyond  $2f$ . How many real images will be obtained on the other side?

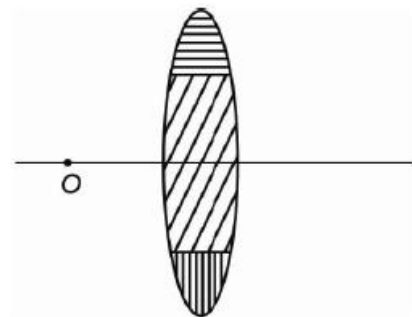

[NEET-2023 (Phase-2)]

- (1) No image will be formed    (2) 3  
 (3) 2                                    (4) 1

45. What is the lateral shift of a ray refracted through a parallel-sided glass slab of thickness 'h' in terms of the angle of incidence 'i' and angle of refraction 'r', if the glass slab is placed in air medium?

[NCERT Page 229]

- (1)  $\frac{h \tan(i-r)}{\tan r}$                       (2)  $\frac{h \cos(i-r)}{\sin r}$   
 (3) h                                    (4)  $\frac{h \sin(i-r)}{\cos r}$

46. Identify the major product of the following reaction  
[NCERT, Page 239]

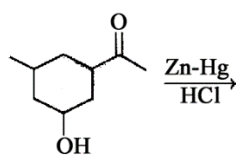

- (1) (2)
- (3) (4)

47. Identify the correct decreasing order of acidic strength.  
[NCERT, Page 207]

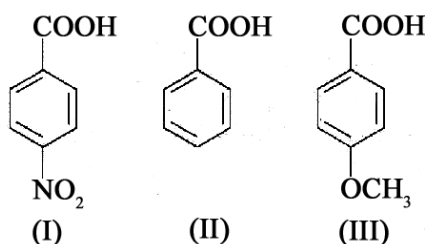

- (1) III > II > I                      (2) I > II > III  
 (3) II > III > I                      (4) I > III > II

48. Consider the following sequence of reactions  
[NCERT, Page 210]

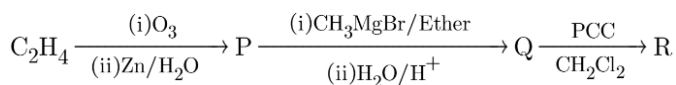

The incorrect statement about R is

- (1) It gives test with Tollen's reagent  
 (2) It undergoes Cannizaro reaction  
 (3) It gives iodoform test  
 (4) It undergoes aldol condensation
49. Match List-I with List-II.

**List-I**

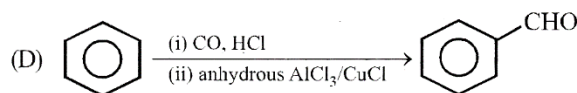
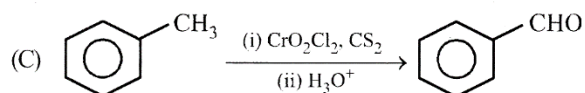
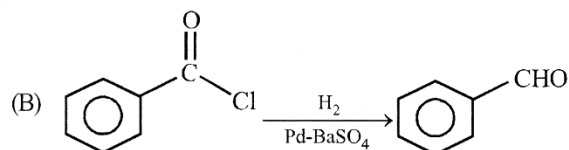
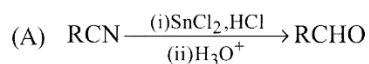

**List-II**

- (p) Etard reaction  
 (q) Gatterman - Koch reaction  
 (r) Rosenmund reduction  
 (s) Stephen reaction

Choose the correct answer from the options given below

- (1) A-(s), B-(r), C-(p), D-(q)  
 (2) A-(r), B-(s), C-(q), D-(p)  
 (3) A-(p), B-(r), C-(q), D-(s)  
 (4) A-(r), B-(s), C-(p), D-(q)

50. X and Y in the following reactions are  
[NCERT, Page 252]

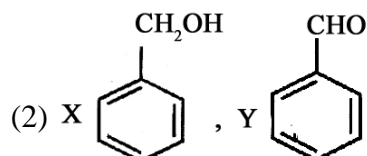
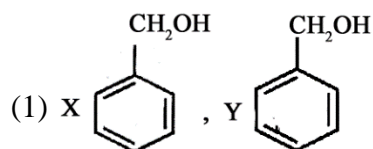
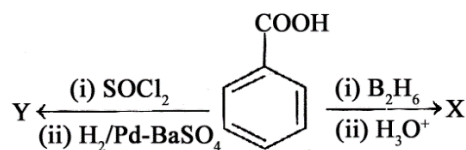

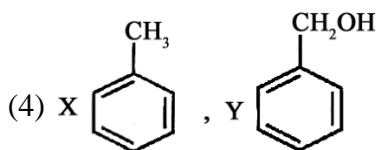
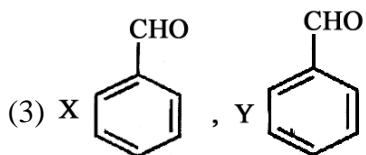

51. Identify the major product from the following reaction sequence [NCERT, Page 253]

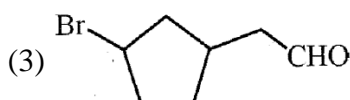
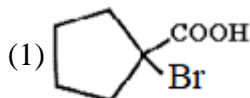
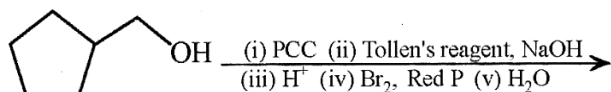

(4) None of these

52. **Statement I:** 2,2-Dimethyl propanal undergoes Cannizzaro reaction with concentrated NaOH.

**Statement II:** Cannizzaro is a disproportionation reaction.

[NCERT, Page 242]

- (1) Both statement I and II are correct.  
 (2) Both statement I and II are incorrect.  
 (3) Statement I is correct but statement II is incorrect.  
 (4) Statement II is correct but statement I is incorrect.
53. **Statement I:** Benzaldehyde can be prepared by oxidation of toluene with acidic  $\text{KMnO}_4$ .

**Statement II:**  $\text{Pd/BaSO}_4$  is used to convert acyl chloride into aldehyde.

[NCERT, Page 232]

- (1) Both statement I and II are correct.  
 (2) Both statement I and II are incorrect.  
 (3) Statement I is correct but statement II is incorrect.

(4) Statement II is correct but statement I is incorrect.

54. Sodium salt of which carboxylic acids on heating with soda lime will produce propane?

[NCERT, Page 253]

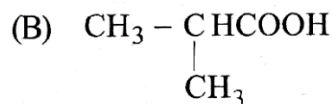
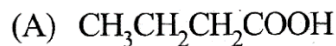

- (1) A, B and C                      (2) B and C only  
 (3) A only                              (4) A and B only

55. **Statement I:** The nucleophilic addition of sodium hydrogen Sulphite to an aldehyde or a ketone involves proton transfer to form a stable ion.

**Statement II:** The nucleophilic addition of hydrogen cyanide to an aldehyde or a ketone yields amine as final product.

[NCERT, Page 237]

- (1) Both statement I and II are correct.  
 (2) Both statement I and II are incorrect.  
 (3) Statement I is correct but statement II is incorrect.  
 (4) Statement II is correct but statement I is incorrect.

56. The number of products obtained in the following reaction is [NCERT, Page 241]

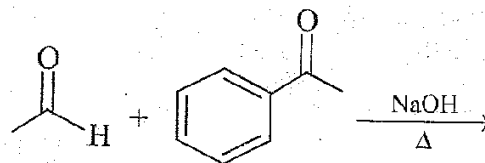

- (1) 1                                      (2) 2  
 (3) 3                                      (4) 4

57. Which of the following conversions can be carried out by Clemmensen reduction?

[NCERT, Page 239]

- (A) Benzaldehyde into benzl alcohol.  
 (B) Cyclohexanone into cyclohexane.  
 (C) Benzyl chloride into benzaldehyde.  
 (D) Benzophenone into diphenyl methane.

- (1) A and D                      (2) A and B  
 (3) B and C                      (4) B and D

58. Identify A and B:

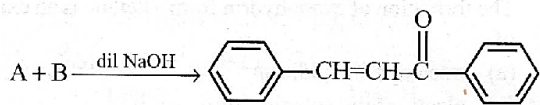

- (1) A = 1-phenylethanal, B = acetophenone  
 (2) A = Benzophenone B = formaldehyde  
 (3) A = Benzaldehyde, B = Acetophenone  
 (4) A = Benzophenone, B = Acetophenone
59. What is IUPAC name of the ketone A, which undergoes iodo form reaction to give  $\text{CH}_3\text{CH}=\text{C}(\text{CH}_3)\text{COONa}$  and yellow precipitate of  $\text{CHI}_3$ ?
- (1) 3-Methylpent-3-en-2-one  
 (2) 3-Methylbut-2-en-one  
 (3) 2,3-Dimethylethanone  
 (4) 3-Methylpent-4-one
60. The reagent that can be used to distinguish acetophenone and benzophenone is
- (1) 2, 4-dinitrophenyl hydrazine  
 (2) aqueous  $\text{NaHSO}_3$   
 (3) Fehling solution  
 (4)  $\text{I}_2$  and  $\text{NaOH}$
61. Which of the following compounds will undergo self-condensation in the presence of dilute  $\text{NaOH}$  solution?
- (1)  $\text{C}_6\text{H}_5\text{CHO}$                       (2)  $\text{CH}_3\text{CH}_2\text{CHO}$   
 (3)  $(\text{CH}_3)_3\text{C}-\text{CHO}$                 (4)  $\text{H}-\text{CHO}$
62. Which of the following tests/reactions is given by aldehydes as well as ketones?
- (1) Fehling's test  
 (2) Tollen's test  
 (3) 2,4 DNP test  
 (4) Cannizzaro reaction
63. The correct set of reagents which convert acetylene to but-2-enal are
- (1)  $\text{H}_2\text{SO}_4$ ,  $\text{NaOH}$

- (2)  $\text{H}_2\text{O}/\text{Hg}^{2+}/\text{H}^+$ , dil.  $\text{NaOH}$   
 (3)  $\text{H}_2\text{O}/\text{H}^+$ , conc.  $\text{NaOH}$   
 (4)  $\text{H}_2\text{O}$ ,  $\text{KMnO}_4/\text{OH}$

64. The general name of the compound formed by the reaction between aldehyde and alcohol is
- (1) glycol                              (2) acetate  
 (3) ester                                (4) acetal
65. Reduction of ketones cannot be carried out with which of the following reagents?
- (1) Hydrogen in presence of palladium in barium sulphate and quinoline  
 (2) Sodium borohydride or lithium aluminium hydride  
 (3) Zinc amalgam and concentrated  $\text{HCl}$   
 (4) Hydrazine and  $\text{KOH}$  in ethylene glycol
66. **Statement I:** The boiling points of aldehydes and ketones are higher than hydrocarbons of comparable molecular masses because of weak molecular association in aldehydes and ketones due to dipole - dipole interactions.
- Statement II:** The boiling points aldehydes and ketones are lower than the alcohols of similar molecular masses due to the absence of H-bonding.
- (1) Both statement I and II are correct.  
 (2) Both statement I and II are incorrect.  
 (3) Statement I is correct but statement II is incorrect.  
 (4) Statement II is correct but statement I is incorrect.
67. Which of the following reactions will give benzophenone as major product?
- (A) Benzoyl chloride + Benzene +  $\text{AlCl}_3$  (anhyd.)  
 (B) Benzoyl chloride + Phenylmagnesium bromide (excess)  
 (C) Benzoyl chloride + Diphenyl cadmium  
 (D) Benzene + Carbon Monoxide +  $\text{ZnCl}_2$
- (1) A and B only                      (2) B and C only  
 (3) A and C only                      (4) A, B, C and D

68. Match the Columns.

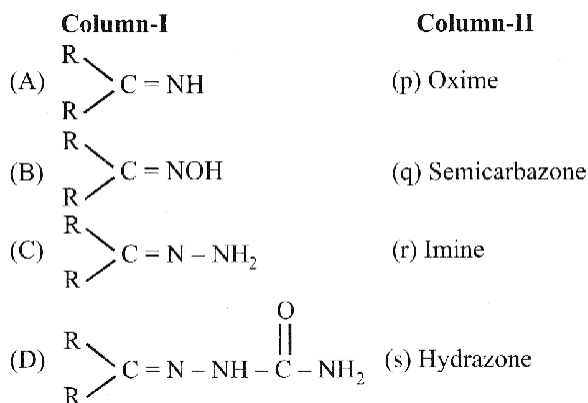

- (1) A-(q), B-(s), C-(p), D-(r)  
 (2) A-(r), B-(p), C-(s), D-(q)  
 (3) A-(r), B-(s), C-(p), D-(q)  
 (4) A-(s), B-(r), C-(q), D-(p)

69. Match the Column.

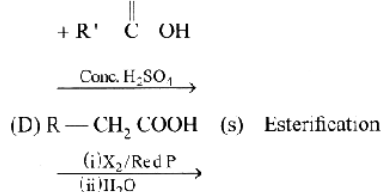
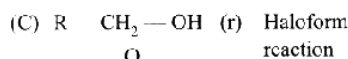
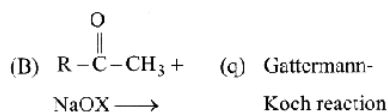
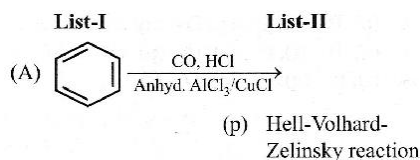

Choose the correct answer from the options given below.

- (1) A-(q), B-(r), C-(s), D-(p)  
 (2) A-(s), B-(p), C-(q), D-(r)  
 (3) A-(r), B-(q), C-(p), D-(s)  
 (4) A-(p), B-(s), C-(r), D-(q)

70. Match List-I with List-II.

List-I (Products formed)	List-II (Reaction of carbonyl compound with)
(A) Cyanohydrin	(p) $\text{NH}_2\text{OH}$
(B) Acetal	(q) $\text{RNH}_2$
(C) Schiff's base	(r) alcohol
(D) Oxime	(s) $\text{HCN}$

Choose the correct answer from the options given below:

- (1) A-(q), B-(r), C-(s), D-(p)  
 (2) A-(p), B-(r), C-(q), D-(s)  
 (3) A-(s), B-(r), C-(q), D-(p)  
 (4) A-(r), B-(s), C-(q), D-(p)

71. The distinguishing test between methanoic acid and ethanoic acid is

- (1) Tollens' test  
 (2) Sodium bicarbonate test  
 (3) Litmus test  
 (4) Esterification test.

72. The reagent which can do the conversion,  $\text{CH}_3\text{COOH} \rightarrow \text{CH}_3-\text{CH}_2-\text{OH}$  is

- (1)  $\text{LiAlH}_4/\text{ether}$  (2)  $\text{H}_2, \text{Pt}$   
 (3)  $\text{NaBH}_4$  (4)  $\text{Na}$  and  $\text{C}_2\text{H}_5\text{OH}$

73. **Statement I:** Carboxylic acids contain a carbonyl group but do not give the characteristic reactions of the group.

**Statement II:** The electrophilicity of the carbon atom is more in carboxylic acids than in aldehydes and ketones.

- (1) Both statement I and II are correct.  
 (2) Both statement I and II are incorrect.  
 (3) Statement I is correct but statement II is incorrect.  
 (4) Statement II is correct but statement I is incorrect.

74. **Assertion:** Formic acid reduces tollens reagent.

**Reason:** Compounds containing CHO group reduces tollens reagent.

- (1) If both Assertion and Reason are correct and the Reason is a correct explanation of the Assertion.  
 (2) If both Assertion and Reason are correct but Reason is not a correct explanation of the Assertion.  
 (3) If the Assertion is correct but Reason is incorrect.

(4) If the Assertion is incorrect and Reason is correct.

75. **Assertion:** Benzoic acid is a weaker acid than acetic acid.

**Reason:** Phenyl group when attached to carbonyl group becomes electron withdrawing.

(1) If both Assertion and Reason are correct and the Reason is a correct explanation of the Assertion.

(2) If both Assertion and Reason are correct but Reason is not a correct explanation of the Assertion.

(3) If the Assertion is correct but Reason is incorrect.

(4) If the Assertion is incorrect and Reason is correct.

76. Match the acids given in Column-I with their correct IUPAC names given in Column-II.

Column-I (Acids)	Column-II (IUPAC names)
(A) Phthalic acid	(p) Hexane-1, 6-dioic acid
(B) Oxalic acid	(q) Benzene-1, 2-dicarboxylic acid
(C) Succinic acid	(r) Ethane-1, 2-dioic acid
(D) Adipic acid	(s) Butane-1, 4-dioic acid

(1) A-(r), B-(q), C-(s), D-(p)

(2) A-(p), B-(s), C-(r), D-(q)

(3) A (q), B-(r), C-(s), D-(p)

(4) A-(r), B-(q), C-(p), D-(s)

77. A compound 'X' on treatment with  $\text{Br}_2/\text{NaOH}$ , provided  $\text{C}_3\text{H}_9\text{N}$ , which gives positive carbylamine test. Compound 'X' is:

(1)  $\text{CH}_3\text{COCH}_2\text{NHCH}_3$

(2)  $\text{CH}_3\text{CH}_2\text{COCH}_2\text{NH}_2$

(3)  $\text{CH}_2\text{CH}_2\text{CH}_2\text{CONH}_2$

(4)  $\text{CH}_3\text{CON}(\text{CH}_3)_2$

78. *p*-Chloroaniline and anilinium hydrogen chloride can be distinguished by

(1) Sandmeyer reaction

(2) Carbylamine reaction

(3) Hinsberg's reaction

(4)  $\text{AgNO}_3$

79. The product (P) formed from the following multistep reaction is:

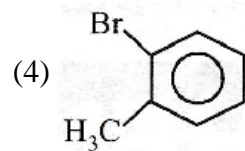
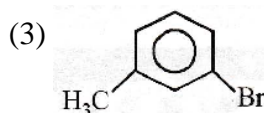
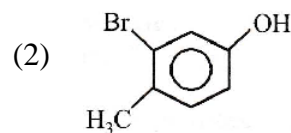
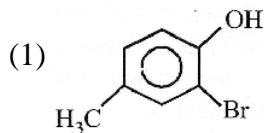
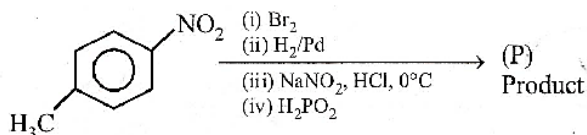

80. Acetanilide on nitration followed by alkaline hydrolysis mainly gives

(1) *o*-Nitroaniline

(2) *p*-Nitroaniline

(3) *m*-Nitroaniline

(d) 2,4,6-Trinitroaniline

81. In order to distinguish between  $(\text{CH}_3)_2\text{NH}$  and  $(\text{CH}_3)_3\text{N}$  which of the following reagent is useful

(1) Hinsberg's reagent (2)  $\text{HNO}_2$

(3)  $\text{CHCl}_3 + \text{KOH}$  (4)  $\text{NaOH}$

82. Identify the product (A) in the following reaction.

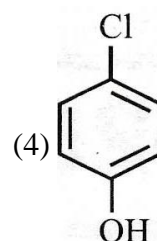
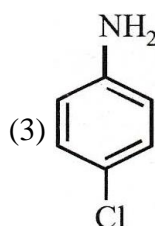
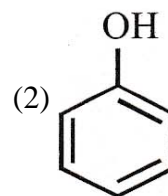
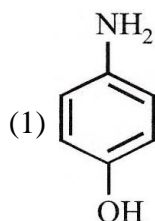
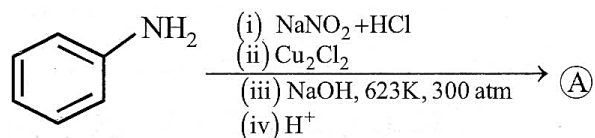

83. Product (B) in this reaction is :

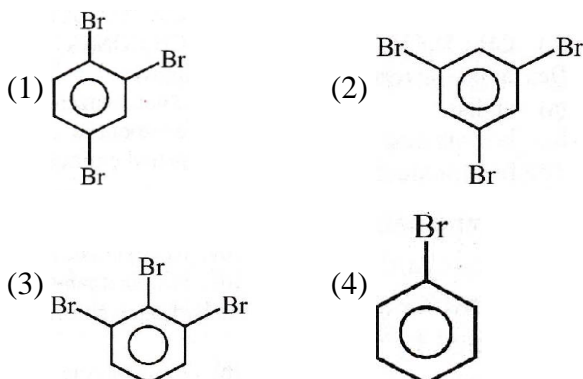
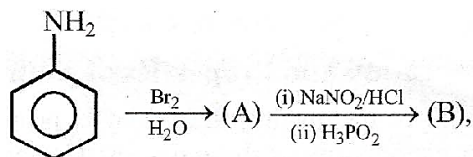

84. The basicity of aniline is less than that of cyclohexylamine. This is due to

- (1) + R effect of  $-\text{NH}_2$  group
- (2)  $-I$  effect of  $-\text{NH}_2$  group
- (3)  $-R$  effect of  $-\text{NH}_2$  group
- (4) hyperconjugation effect

85. Consider the given reaction, percentage yield of:

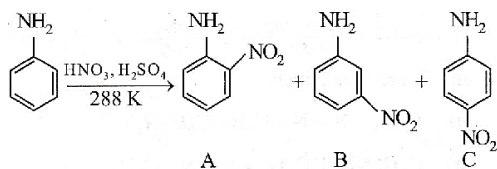

- (1)  $C > B > A$
- (2)  $C > A > B$
- (3)  $B > C > A$
- (4)  $A > C > B$

86. **Assertion:** Experimental reaction of  $\text{CH}_3\text{Cl}$  with aniline and anhydrous  $\text{AlCl}_3$  does **not** give *o* and *p*-methylaniline.

**Reason:** The  $-\text{NH}_2$  group of aniline becomes deactivating because of salt formation with anhydrous  $\text{AlCl}_3$  and hence yields *m*-methyl aniline as the product.

- (1) If both Assertion and Reason are correct and the Reason is a correct explanation of the Assertion.
- (2) If both Assertion and Reason are correct but Reason is not a correct explanation of the Assertion.
- (3) If the Assertion is correct but Reason is

incorrect.

- (4) If the Assertion is incorrect and Reason is correct.

87. Match Column I with Column II.

Column-I	Column-II
(A) Benzenesulphonyl chloride	(p) Test for primary amines
(B) Hoffmann bromamide reaction	(q) Anti Saytzeff reaction
(C) Carbylamine reaction	(r) Hinsberg reagent
(D) Hoffmann Elimination	(s) Preparation of primary amines

Choose the correct answer from the options given below:

- (1) A-(s), B-(r), C-(q), D-(p)
- (2) A-(s), B-(q), C-(p), D-(r)
- (3) A-(r), B-(s), C-(p), D-(q)
- (4) A-(s), B-(r), C-(p), D-(q)

88. Match Column I with Column II.

Column-I	Column-II
(A) Benzene sulphonyl chloride	(p) Zwitter ion
(B) Sulphanilic acid	(q) Hinsberg reagent
(C) Alkyl diazonium salts	(r) Dyes
(D) Aryl diazonium salts	(s) Conversion to alcohols

- (1) A-(s), B-(q), C-(r), D-(p)
- (2) A-(q), B-(p), C-(s), D-(r)
- (3) A-(r), B-(s), C-(p), D-(q)
- (4) A-(s), B-(p), C-(r), D-(q)

89. Aniline in a set of the following reactions yielded a coloured product 'Y'. The structure of 'Y' would be ;

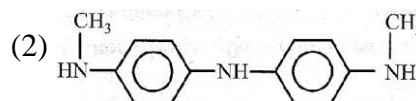
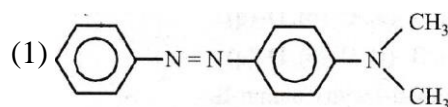
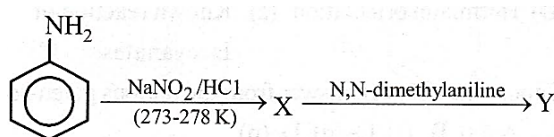

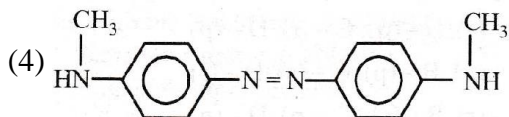
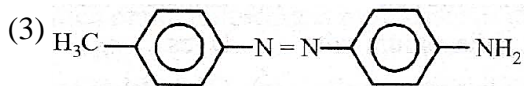

90. Match List-I with List-II.

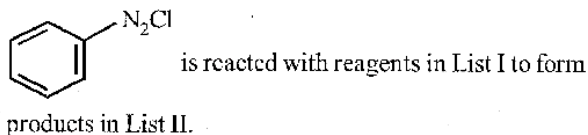

**List-I**  
(Reagent)

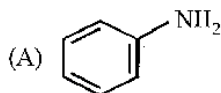

**List-II**  
(Product)

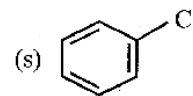
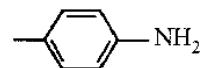
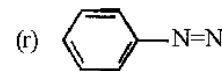
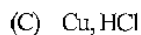
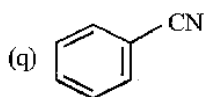
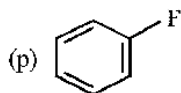

(1) A-(s), B-(r), C-(q), D-(p)

(2) A-(p), B-(r), C-(s), D-(q)

(3) A-(r), B-(p), C-(q), D-(s)

(4) A-(r), B-(p), C-(s), D-(q)

## BOTANY

91. Conversion of milk to curd improves its nutritional value by increasing the amount of

- (1) Vitamin B12                      (2) Vitamin A  
(3) Vitamin D                        (4) Vitamin E

92. *Lactobacillus* mediated change of milk to curd occurs due to

- (1) Coagulation and partial digestion of milk fats  
(2) Coagulation and partial digestion of milk proteins  
(3) Coagulation of milk proteins and complete digestion of milk fats  
(4) Coagulation of milk proteins and complete digestion of milk proteins

93. **Statement I:** 'Roquefort Cheese' is ripened by using bacteria.

**Statement II:** Microbe yielding 'clot buster' for myocardial infraction is *Streptomyces* species.

- (1) Both statement I and II are true.  
(2) Both statement I and II are false.  
(3) Statement I is true but statement II is false.  
(4) Statement I is false but statement II is true.

94. **Assertion A:** Toddy is fermenting drink of southern India.

**Reason R:** Made by fermenting sap from palms.

(1) Both A and R are true and R is the correct explanation of A.

(2) Both A and R are true but R is NOT the correct explanation of A.

(3) A is true but R is false.

(4) A is false but R is true

95. Match the Columns :

**Column-I**

**Column-II**

A. Curd

(i) LAB

B. Streptokinase

(ii) *Penicillium*

C. Statin

(iii) *Streptococcus*

D. Cheese

(iv) *Monascus purpureus*

(1) A-(i), B-(iii), C-(iv), D-(ii)

(2) A-(i), B-(iv), C-(ii), D-(iii)

(3) A-(iv), B-(ii), C-(i), D-(iii)

(4) A-(ii), B-(iv), C-(iii), D-(i)

96. Cyclosporin A is produced from-
- (1) *Trichoderma polysporum* (a fungus)
  - (2) *Bacillus* (a bacterium)
  - (3) *Aspergillus* (a fungus)
  - (4) all of these
97. Which one(s) is/are correct about Cyclosporin A?
- (1) It is produced by the fungus *Trichoderma polysporum*
  - (2) It is used as an immuno suppressive agent during organ transplantation
  - (3) It is produced by a type of yeast, *Monascus purpureus*
  - (4) Both (1) and (2)
98. Which of the following is correctly matched for the product produced by them?
- (1) Methanobacterium: Lactic acid
  - (2) Penicillium notatum: Acetic acid
  - (3) Saccharomyces cerevisiae: Ethanol
  - (4) Acetobacter aceti: Antibiotics
99. Choose the incorrect statement:
- (1) The first antibiotic was penicillin
  - (2) Lactic acid was the first organic acid produced by lactobacillus
  - (3) Alexander Fleming working on *staphylococci*
  - (4) *Rhizobium* and *frankia* symbiotic association with the roots of legume plants
100. **Statement I:** Brandy, Whisky & Rum are produced without distillation of fermented broth.
- Statement II:** The large holes in 'Swiss cheese' are because of *Propionibacterium sharmanii*.
- (1) Both statement I and II are true.
  - (2) Both statement I and II are false.
  - (3) Statement I is true but statement II is false.
  - (4) Statement I is false but statement II is true.
101. Read the following statements:
- (i) Statins are produced by some yeasts
  - (ii) Statins are blood cholesterol lowering agents

- (iii) Statins produced from *Monascus purpureus*
- (iv) Statins acts competitively inhibiting the enzymes responsible for synthesis of cholesterol
- (v) Statins are immunosuppressive agents

Which of the above statements are correct?

- (1) (i), (ii), (iii) and (iv) only
- (2) (i), (ii) and (v) only
- (3) (iii), (iv) and (v) only
- (4) (ii), (iii), (iv) and (v) only

102. **Assertion A:** Cyclosporin-A is an immunosuppressive agent which is given to individuals undergoing organ transplantation.

**Reason R:** Cyclosporin-A suppresses the activation of T-cells and prevents rejection.

- (1) Both A and R are true and R is the correct explanation of A.
- (2) Both A and R are true but R is NOT the correct explanation of A.
- (3) A is true but R is false.
- (4) A is false but R is true

103. Match the following columns and select the correct option.

	Column I		Column II
A.	<i>Clostridium butylicum</i>	(i)	Cyclosporin-A
B.	<i>Trichoderma polysporum</i>	(ii)	Butyric acid
C.	<i>Monascus purpureus</i>	(iii)	Citric acid
D.	<i>Aspergillus niger</i>	(iv)	Blood cholesterol lowering agent

- (1) A(iii), B (iv), C (ii), D- (i)
- (2) A(ii), B(i), C (iv), D- (iii)
- (3) A(i), B(ii), C (iv), D- (iii)
- (4) A(iv), B (iii), C (ii), D- (i)

104. Match the microbes given in column I with the major role played by them given in column II and select the correct option from the codes given below.

	Column I (Microbes)		Column II (Function)
A.	<i>Propionibacterium shermanii</i>	(i)	Produces an immune suppressive agent
B.	<i>Streptococcus</i>	(ii)	Nitrogen fixation in soil
C.	<i>Trichoderma polysporum</i>	(iii)	Produce large holes in Swiss cheese
D.	Rhizobium	(iv)	Produces enzyme used as clot-buster

- (1) A-(iii), B-(i), C-(iv), D-(ii)  
 (2) A-(iii), B-(iv), C-(i), D-(ii)  
 (3) A-(ii), B-(iv), C-(i), D-(iii)  
 (4) A-(i), B-(iii), C-(ii), D-(iv)

**105.** The solids which settle after primary treatment of sewage are called

- (1) primary sludge                      (2) activated sludge  
 (3) flocs                                      (4) total solids

**106.** The below diagram shows a typical biogas plant. Which of the following four option, products labelled as A, B and C are correctly identified-

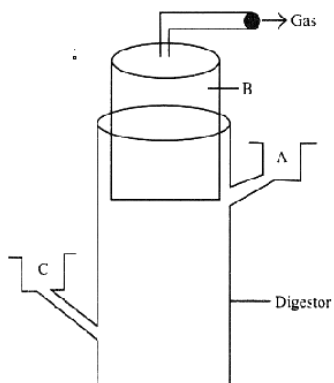

- (1) A-Sludge; B-Methane, Oxygen; C-Dung, water  
 (2) A-Sludge; B-Methane, CO<sub>2</sub>; C-Dung, water  
 (3) A-Sludge; B-Methane, SO<sub>4</sub>; C-Dung, water  
 (4) A-Sludge; B-Methane, H<sub>2</sub>S; C-Dung, water

**107.** Baculoviruses (Nucleopolyhedrovirus) does not show

- (1) Host specificity  
 (2) Narrow spectrum applications

- (3) Effects on non-target pathogens  
 (4) Utility in IPM programme

**108.** Which one of the following is an example of carrying out biological control of pests/diseases using microbes?

- (1) *Trichoderma* sp. against white rust in *Brassica*  
 (2) *Nucleopolyhedrovirus* against white rust in *Brassica*  
 (3) Bt- cotton to decrease cotton yield  
 (4) Lady bird beetle against aphids

**109.** A biocontrol agent to be a part of an integrated pest management should be

- (1) Species-specific and inactive on non target organisms  
 (2) Species-specific and symbiotic  
 (3) Free living and broad spectrum  
 (4) Narrow spectrum and symbiotic

**110.** Read the following statements:

- (i) Biofertilisers like cyanobacteria used in fields  
 (ii) Microbe are important role in human welfare  
 (iii) Bt-cotton is a transgenic crop  
 (iv) *Clostridium* is the most active symbiotic nitrogen fixer in Indian wheat fields  
 (v) *Trichoderma*, a blue green algae, is used as an excellent biofertilizer in the rice fields

Which of the above statements are correct?

- (1) (i), (ii) and (iii) only  
 (2) (iv) and (v) only  
 (3) (iii), (iv) and (v) only  
 (4) (i), (iv) and (v) only

**111.** Match the Column I with Column II.

	Column I		Column II
A.	<i>Trichoderma</i>	(i)	Biofertiliser
B.	Rhizobium	(ii)	Aphids
C.	<i>Bacillus thuringiensis</i>	(iii)	Bio-insecticide
D.	Lady bird	(iv)	Biological control of root born disease

- (1) A-(iv), B-(i), C-(iii), D-(ii)
- (2) A-(i), B-(iv), C-(ii), D-(iii)
- (3) A-(ii), B-(iv), C-(i), D-(iii)
- (4) A-(iii), B-(i), C-(iv), D-(ii)

**112.** Urn-shaped is pyramid represents :

- (1) Growing population
- (2) Declining population
- (3) Highly dynamic population
- (4) Unpredictable

**113.** The population explosion that occurred shortly after the prickly pear cactus (*Opuntia*) introduced to Australia in early 1920's is an example of-

- (1) Exponential growth
- (2) Emigration
- (3) A native species outcompeting an introduced species
- (4) Immigration

**114.** In an area, there are 200 *Parthenium* and a single huge banyan tree. Which of the following conclusions is correct?

- (1) Population density of banyan is low relative to that of *Parthenium*.
- (2) Population cover area of banyan is high relative to *Parthenium*.
- (3) In the above case % cover or biomass is a more meaningful measure of the population size.
- (4) All the above

**115.** The age structure of a population is its-

- (1) Relative number of individuals at each age
- (2) Number of newborns each year
- (3) Number of newborns each year
- (4) Relative number of deaths at each age

**116.** For which of the following cases, population density can be easily determined by utilizing non-biological parameter?

- (1) Fish density
- (2) Density of bacteria in culture plate

- (3) Siberian cranes at Bharatpur wetlands
- (4) Tiger census

**117.** Population growth of a species is not related to which of the following parameters?

- (1)  $N_{t+1} = N_t + [(B + 1) - (D + E)]$
- (2) Out of the four basic processes effecting population growth three leads to increase in population size
- (3) For a newly colonised habitat immigration plays major role than birth rate
- (4) Under normal conditions, natality and mortality are the most important factors

**118.** As the number of individuals approaches the carrying capacity of a population, which of the following is predicted by the sigmoidal growth curve?

- (1) Population biomass will remain the same
- (2) Population density will increase exponentially
- (3) Population growth rate will decrease
- (4) Population growth rate will increase

**119.** Go through the population growth formula

$$\frac{dn}{dt} = rN ; r - \text{represents :}$$

- (1) Time
- (2) Population size
- (3) Biotic potential
- (4) Per capita birth rate only

**120.** Choose the correct option-

- (1) Geometric growth produces J-shaped population growth curve
- (2) Logistic growth occurs when resources are limiting
- (3) For exponential growth equation is  $N_t = N_0 e^{rt}$
- (4) All

**121.** Environmental resistance is denoted by :

- (1)  $\left(\frac{K-N}{K}\right)$
- (2)  $\left(\frac{K+N}{K}\right)$
- (3)  $rN$
- (4)  $rN \left(\frac{K+N}{K}\right)$

122. Vital index of a population is denoted by :

- (1)  $\frac{N}{M} \times 100$                       (2)  $(N - M) \times 100$   
 (3)  $(M/N)$                               (4)  $\frac{M}{N} \times 100$

123. **Assertion A:** Population size, technically called population density need not necessarily be measured in numbers only.

**Reason R:** The size of the population tells us a lot about its status in the habitat.

- (1) Both A and R are true and R is the correct explanation of A.  
 (2) Both A and R are true but R is NOT the correct - explanation of A.  
 (3) A is true but R is false.  
 (4) A is false but R is true.

124. Identify I to IV

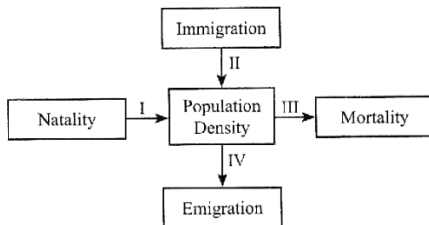

- | I            | II       | III      | IV       |
|--------------|----------|----------|----------|
| (1) Increase | Decrease | Increase | Decrease |
| (2) Decrease | Increase | Decrease | Increase |
| (3) Increase | Increase | Decrease | Decrease |
| (4) Decrease | Decrease | Increase | Increase |

125. Identify 'a' in a figure.

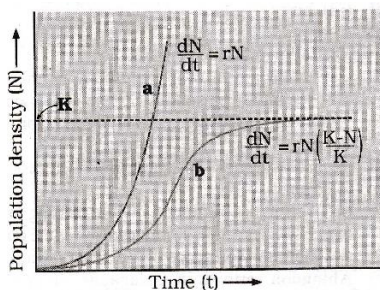

- (1) Exponential growth    (2) Logistic growth  
 (3) Time                      (4) Population density

126. In certain shallow lake of South America, the visiting flamingoes and resident fishes compete for their food.

- (1) phyplanktons                      (2) Zooplanktons

- (3) Smaller fishes                      (4) Ulothrix

127. **Statement I:** Predators helps in maintaining species diversity in a community.

**Statement II:** The interaction between the orchid and mango tree is an example for commensalism.

- (1) Both statement I and II are true.  
 (2) Both statement I and II are false.  
 (3) Statement I is true but statement II is false.  
 (4) Statement I is false but statement II is true.

128. Read the following statements:

- (i) Cattles do not browse Calotropis as these plants produce highly poisonous cardiac glycosides  
 (ii) Totally unrelated species can compete for the same resource  
 (iii) Resources need not always be limiting for competition to occur  
 (iv) In 'Interference competition', the feeding efficiency of one species might be reduced due to the interfering and inhibitory presence of the other species  
 (v) Abingdon tortoise in Galapagos islands became extinct within a decade after goats were introduced, apparently due to the greater browsing efficiency of goats

How many of the above statements are correct?

- (1) Four                                      (2) Five  
 (3) Two                                      (4) Three

129. **Assertion A:** Predators in nature are prudent.

**Reason R:** If predators overexploit it's prey, predators also become extinct due to lack of food.

- (1) Both A and R are true and R is the correct explanation of A.  
 (2) Both A and R are true but R is NOT the correct - explanation of A.  
 (3) A is true but R is false.  
 (4) A is false but R is true.

**130. Assertion A:** Interspecific competition is a potent force in organic evolution.

**Reason R:** Competition generally occurs when closely related species compete for same resources.

- (1) Both A and R are true and R is the correct explanation of A.
- (2) Both A and R are true but R is NOT the correct - explanation of A.
- (3) A is true but R is false.
- (4) A is false but R is true.

**131.** Match the column I and II.

Column –I	Column - II
(A) Parasitism	(i) ++
(B) Commensalism	(ii) +-
(C) Amensalism	(iii) 0 +
(D) Mutualism	(iv) 0 –

- (1) (A)-(iii), (B)-(ii), (C)-(iv), (D)-(i)
- (2) (A)-(i), (B)-(ii), (C)-(iii), (D)-(iv)
- (3) (A)-(ii), (B)-(iii), (C)-(i), (D)-(iv)
- (4) (A)-(ii), (B)-(iii), (C)-(iv), (D)-(i)

**132.** Match the Columns I and II, and choose the correct combination from the options given.

	Column I		Column II
A.	<i>Camouflaged</i>	(i)	<i>Acacia</i>
B.	Distasteful	(ii)	<i>Calotropis</i>
C.	Thorns	(iii)	Monarch butterfly
D.	Cardiac glycosides	(iv)	Frogs

- (1) (A)-(iv), (B)-(iii), (C)-(ii), (D)-(i)
- (2) (A)-(iv), (B)-(iii), (C)-(i), (D)-(ii)
- (3) (A)-(iv), (B)-(ii), (C)-(i), (D)-(iii)
- (4) (A)-(iii), (B)-(iv), (C)-(i), (D)-(ii)

**133.** Match the Columns and choose the correct options.

	Column I		Column II (Function)
A.	Mutualism	(i)	Ticks on dogs
B.	Parasitism	(ii)	Balanus
C.	Competition	(iii)	Sparrow eating any seed
D.	Predation	(iv)	Ophrys and bee

- (1) (A)-(iv), (B)-(i), (C)-(ii), (D)-(iii)
- (2) (A)-(ii), (B)-(i), (C)-(iii), (D)-(iv)
- (3) (A)-(iii), (B)-(ii), (C)-(i), (D)-(iv)
- (4) (A)-(iv), (B)-(iii), (C)-(ii), (D)-(i)

**134.** Enzyme which has the removing oily stains effect, is-

- (1) Protease
- (2) Amylase
- (3) Lipase
- (4) Streptokinase

**135.** Types of alcoholic beverages obtained depend on-

- (1) Raw materials used for fermentation
- (2) Types of processing
- (3) Both (1) and (2)
- (4) Type of storage pattern

## ZOOLOGY

136. From the statements given below choose the correct option: [NCERT Page 130-132]

- A. *Haemophilus influenzae* infects the alveoli of lungs.
- B. Intestinal perforation and death may occur in severe cases of typhoid.
- C. Rhino virus infect the nose and respiratory passage but not the lungs.
- D. Symptoms of amoebiasis are joint pain and excess mucous from nose.

- (1) B, C and D only      (2) A and C only  
(3) A, C and D only      (4) A, B, C only

137. Which one of the following statement is correct?

[NCERT Page 138, 141-143]

- A. Spleen is primary lymphoid organ
- B. Patients who have undergone surgery are given cannabinoids to relieve pain
- C. Malignant tumors exhibit metastasis
- D. Heroin accelerates body functions
- E. Benign tumors show the property of metastasis

Choose the correct answer from the options given below:

- (1) A and B only      (2) C, D and E only  
(3) C only      (4) A and D only

138. Haemozoin are released as a result of

[NCERT Page 131]

- (1) Rupture of RBCS
- (2) Rupture of liver cells
- (3) Multiplication of sporozoites
- (4) Rupture of WBC

139. Malaria is a [NCERT Page 131]

- (1) Viral disease      (2) Bacterial disease
- (3) Fungal disease      (4) Protozoan disease

140. Match List-I with List-II.

[NCERT Page 131-134]

### List-I

- A. Amoebiasis
- B. Common cold
- C. Dengue
- D. Ringworm

### List-II

- I. Trichoderma
- II. Entamoeba
- III. Rhino virus
- IV. Aedes mosquito

Choose the correct answer from the options given below:

- (1) A-I, B-II, C-III, D-IV
- (2) A-II, B-III, C-IV, D-I
- (3) A-I, B-II, C-IV, D-III
- (4) A-II, B-IV, C-I, D-III

141. Cirrhosis of liver is due to [NCERT Page 146]

- (1) Accumulation of bile in liver due to obstruction
- (2) Use of drugs and alcohol
- (3) Cancer of liver
- (4) Swelling of liver

142. \_\_\_\_\_ is a CNS stimulant as it interferes with the transport of the neuro-transmitter \_\_\_\_\_ .

[NCERT Page 143]

- (1) Cocaine, acetylcholine
- (2) Barbiturate, glutamate
- (3) Cocaine, dopamine
- (4) Barbiturate, glycine

143. From the statements given below choose the correct option:

[NCERT Page 133, 137, 140, 141]

- A. *Wuchereria* is common round worm which causes ascariasis.
- B. Heat and moisture help fungi to grow.
- C. The antibodies produced due to allergens are of IgD type.
- D. A widely used diagnostic confirming test for AIDS is ELISA.

- E. CT and MRI are very useful to detect cancers of the internal organs.  
 (1) A and E only                      (2) A, B and D only  
 (3) B and E only                      (4) A, D and E only
- 144.** From the statements given below choose the correct option: **[NCERT Page 143]**  
 A. These days cannabinoids are being abused by some sports persons.  
 B. Cannabinoids interact with their receptors present principally in the brain.  
 C. Cocaine produces a sense of euphoria and increased energy.  
 D. Cannabinoids are obtained from coca plant.  
 (1) A and B only                      (2) A and C only  
 (3) B and D only                      (4) A, B and C only
- 145.** In the humoral immune response, B lymphocytes produces **[NCERT Page 135]**  
 (1) Antigens                              (2) Army of proteins  
 (3) Collagens                              (4) Allergens
- 146.** Given below are two statement: One is labelled as Assertion (A) and the other is labelled as Reason (R). **[NCERT Page 135]**  
**Assertion (A):** Cannabis sativa is a powerful anti-depressant.  
**Reason (R):** Hashish and marijuana are derived from it.  
 In the light of the above statements, choose the correct answer from the options given below:  
 (1) Both A and R are true and R is the correct explanation of A.  
 (2) Both A and R are true but R is NOT the correct explanation of A.  
 (3) A is true but R is false.  
 (4) A is false but R is true.
- 147.** Lymphoid organ where all blood cells including lymphocytes are produced is **[NCERT Page 138]**  
 (1) Spleen                                  (2) Bone marrow  
 (3) Tonsils                                  (4) Peyer's Patches
- 148.** Typhoid is a **[NCERT Page 130]**  
 (1) Fungal disease                      (2) Bacterial disease  
 (3) Viral disease                        (4) Protozoan disease
- 149.** Identify the correct pair. **[NCERT Page 142, 143]**  
 (1) Dopamine-Hallucinogen  
 (2) Benzodiazepines-Neurotransmitter  
 (3) Amphetamine-Depression  
 (4) Heroin-*Erythroxyllum*
- 150.** Which of the following is an example of physiological barrier of innate immunity? **[NCERT Page 134]**  
 (1) PMNL                                  (2) Interferons  
 (3) Mucus                                  (4) Tears from eyes
- 151.** Appearance of dry, scaly lesions on various parts of the body is caused by which species? **[NCERT Page 133]**  
 (1) *Entamoeba to histolytica*  
 (2) *Microsporium*  
 (3) *Haemophilus influenzae*  
 (4) *Wuchereria bancrofti*.
- 152.** Given below are two statement: one is labelled as Assertion (A) and the other is labelled as Reason (R): **[NCERT Page 144]**  
**Assertion (A):** Tobacco smoking increases heart rate.  
**Reason (R):** Tobacco contains large number of chemical substances like nicotine stimulates adrenal gland to release adrenaline which increases blood pressure and heart rate. In the light of the above statements, choose the correct answer from the options given below:  
 (1) Both A and R are true and R is the correct explanation of A.  
 (2) Both A and R are true but R is NOT the correct explanation of A.  
 (3) A is true but R is false.  
 (4) A is false but R is true.

153. Which of the following diseases are is NOT transferred through viruses.

[NCERT Page 131, 133]

- (1) AIDS (2) Chikungunya  
(3) Common cold (4) Filariasis

154. Primary response of immunity is of

[NCERT Page 135]

- (1) High intensity (2) Low intensity  
(3) No intensity (4) Bad response

155. The symptoms caused by chikungunya virus include

[NCERT Page 134]

- (1) Fever and joint pain  
(2) Diarrhea  
(3) Vomiting  
(4) Indigestion

156. Identify the given plant with name and function its respectively.

[NCERT Page 143]

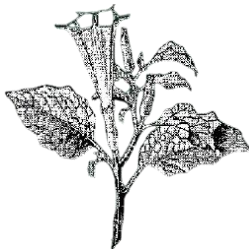

- (1) *Erythroxylum coca*, interfares with dopamine.  
(2) *Cannabis sativa* reduces fever  
(3) *Datura*, act as pain killer  
(4) *Tobacco*, increases heart rate

157. Match List-I with List-II.

[NCERT Page 131, 132, 134]

List-I

List-II

- A. Malaria I. Female Aedes mosquito  
B. Filariasis II. Female Anopheles mosquito  
C. Dengue III. Female mosquito vectors  
D. Chikungunya IV. Chikungunya Virus

Choose the correct answer from the options given below:

(1) A-II, B-III, C-1, D-IV

(2) A-IV, B-III, C-I, D-II

(3) A-III, B-IV, C-II, D-I

(4) A-III, B-IV, C-I, D-II

158. Identify the statement that is NOT correct.

[NCERT Page 135, 136, 138]

- (1) Response of antibodies is also called humoral immune response.  
(2) Colostrum provide passive immunity.  
(3) B-lymphocytes produces an army of protein in response to pathogens in our blood to fight against them.  
(4) Spleen, tonsils and Peyer's patches of small intestine and appendix are primary lymphoid organs.

159. Select the symptoms of the diseases caused by round worm.

[NCERT Page 133]

- (1) Internal bleeding and scaly lesions on various parts of body  
(2) Muscular pain and sustained high fever  
(3) Fever, anemia and internal bleeding  
(4) Runny nose and sustained high fever

160. Given below are two statement: One is labelled as Assertion (A) and the other is labelled as Reason (R)

[NCERT Page 132]

**Assertion (A):** *Plasmodium* enters the human body as sporozoites through the bite of infected female *Anopheles* mosquito.

**Reason (R):** Mature sporozoites escape from gut and migrate to the mosquito salivary glands.

In the light of the above statements, choose the correct answer from the options given below:

- (1) Both A and R are true and R is the correct explanation of A.  
(2) Both A and R are true but R is NOT the correct explanation of A.  
(3) A is true but R is false.  
(4) A is false but R is true.

161. Which of the following drug has effect on cardiovascular system of the body?

[NCERT Page 143]

- (1) hashish (2) smack  
 (3) cocaine (4) morphine

162. Identify the marking A, B, C and D in the figure given below and select the correct option.

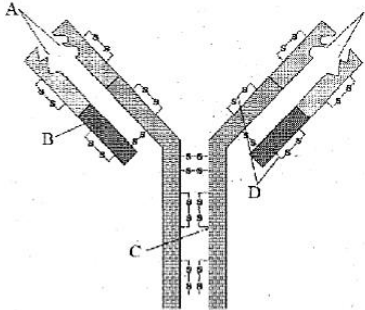

[NCERT Page 135]

- (1) A-Light chains, B-Heavy chains, C-Antigen binding sites, D-Disulphide bonds  
 (2) A-Disulphide bonds, B-Antigen binding site, C-Heavy chain, D-Light chains  
 (3) A-Antigen binding sites, B-Light chain, C-Heavy chain, D-Disulphide bonds  
 (4) A-Antigen binding sites, B-Disulphide bonds, C-Light chain, D-Heavy chains

163. Match List-I with List-II.

[NCERT Page 142, 143]

List-I	List-II
A. Morphine	I. Affects cardio vascular system
B. Cocaine	II. Sedative and painkiller
C. Charas	III. Depressant
D. Heroin	IV. Euphoria

Choose the correct answer from the options given below:

- (1) A-I, B-II, C III, D-IV  
 (2) A-III, B-I, C-IV, D-II  
 (3) A-II, B-IV, C-I, D-III  
 (4) A-IV, B-III, C II, D-I

164. Given below are two statements:

[NCERT Page 144]

**Statement I:** Tobacco chewing is associated

with increased risk of cancer of the oral cavity.

**Statement II:** Smoking reduces the concentration of haembound oxygen.

In the light of the above statements, choose the most appropriate answer from the options given below:

- (1) Both statement 1 and statement II are correct.  
 (2) Both statement I and statement II are incorrect.  
 (3) Statement I is correct but statement II is incorrect.  
 (4) Statement I is incorrect but statement II is correct.

165. Match List-I with List-II.

[NCERT Page 130, 131, 133]

List-I	List-II
A. Typhoid	I. <i>Wuchereria</i>
B. Pneumonia	II. <i>Plasmodium</i>
C. Filariasis	III. <i>Salmonella</i>
D. Malaria	IV. <i>Haemophilus</i>

Choose the correct answer from the options given below:

- (1) A-III; B-IV; C-I; D II  
 (2) A-II; B-I; C-III; D-IV  
 (3) A-IV; B-I; C-II; D-III  
 (4) A-I; B-III; C-II; D-IV

166. Match List-I with List-II. [NCERT Page 136]

List-I	List-II
A. Active	I. Ready-made antibodies immunity
B. Colostrum	II. Yeast
C. Passive immunity	III. Slow
D. Hepatitis B vaccine	IV. IgA

Choose the correct answer from the options given below:

- (1) A-IV; B-III; C-I; D-II (2) A-III; B IV; C-II; D-I  
 (3) A-III; B-IV; C-1; D-II (4) A-IV; B-III; C II; D-I

167. Given below are two statements:

[NCERT Page 135]

**Statement I:** Virus infected cells secrete proteins called interferons.

**Statement II:** Interferons protect infected cells from further viral infection.

In the light of the above statements, choose the most appropriate answer from the options given below:

- (1) Both statement I and statement II are correct.
- (2) Both statement I and statement II are incorrect.
- (3) Statement I is correct but statement II is incorrect.
- (4) Statement I is incorrect but statement II is correct.

168. Match List-I with List-II.

[NCERT Page 137, 141]

**List-I**

- A. Auto-immunity
- B. Allergic disease
- C. Contact inhibition
- D. Metastasis

**List-II**

- I. Rheumatoid arthritis
- II. Asthma
- III. Normal cells
- IV. Malignant tumours

Choose the correct answer from the options given below:

- (1) A-I, B-II, C-III, D-IV
- (2) A-I, B-II, C-IV, D-III
- (3) A-II, B-I, C-III, D-IV
- (4) A-II, B-I, C-IV, D-III

169. \_\_\_\_\_ trap blood borne micro-organisms

[NCERT Page 137, 141]

- |              |                 |
|--------------|-----------------|
| (1) Spleen   | (2) Bone marrow |
| (3) Appendix | (4) Tonsils     |

170. Given below are two statements: One is labelled as Assertion (A) and the other is labelled as Reason (R):

**Assertion (A):** Pathogens have to adapt to life

within the environment of the surviving host.

**Reason (R):** Pathogens that enter the gut must know a way of surviving in the stomach at low pH.

In the light of the above statements, choose the correct answer from the options given below:

[NCERT Page 137, 141]

- (1) Both A and R are true and R is the correct explanation of A.
- (2) Both A and R are true but R is NOT the correct explanation of A.
- (3) A is true but R is false.
- (4) A is false but R is true.

171. Given below are two statements:

[NCERT Page 137]

**Statement I:** Autoimmune disorder is a condition where body defense mechanism recognises its own cells as foreign bodies.

**Statement II:** Rheumatoid arthritis is a condition where body does not attack self cells.

In the light of the above statements, choose the most appropriate answer from the options given below:

- (1) Both statement I and statement II are correct.
- (2) Both statement I and statement II are incorrect.
- (3) Statement I is correct but statement II is incorrect.
- (4) Statement I is incorrect but statement II is correct.

172. From the statements given below choose the correct option: [NCERT Page 142, 143]

- A. Heroin, commonly called smack, is obtained by acetylation of morphine.
- B. Cocaine is obtained from the latex of *Papaver somniferum*.
- C. Marijuana interferes with the transmission of dopamine.
- D. Morphine is an effective sedative and pain killer.
- E. Coca alkaloid is chemically diacetyl morphine.

- (1) A and B only                      (2) A and D only  
 (3) B and C only                      (4) C and E only

**173.** Match List-I with List-II. [NCERT Page 142, 143]

<b>List-I</b>	<b>List-II</b>
A. Heroin	I. Euphorian effect
B. Cocaine	II. Cannabis
C. Hashish	III. Depressant
D. Barbiturates	IV. Treatment of insomnia

Choose the correct answer from the options given below:

- (1) A-III; B-I, C-II; D-IV    (2) A-I: B-II; C-III; D-IV  
 (3) A-III; B-II; C-I; D-IV    (4) A-I:B-III; C-II; D-IV

**174.** What is the term for masses of bacteria associated with fungal filaments that form mesh-like structures? [NCERT Page 151]

- (1) Biofilm                              (2) Floc  
 (3) Mycelium                            (4) Sludge

**175.** Identify the statement that is NOT correct.

- (1) Treatment of AIDS with anti-retroviral drug is only cure.  
 (2) Transformation of normal cells into cancerous cells may be induced by physical, chemical or biological agents.  
 (3) Antibodies against cancer specific antigens are also used for detection of certain cancers.  
 (4) Health is a state of complete physical, mental, social and psychological well being.

**176.** Major cause of lung cancer by tobacco smoking is due to [NCERT Page 141]

- (1) Chemical carcinogens    (2) X-rays  
 (3) UV rays                          (4) Physical agents

**177.** Given below are two statement: One is labelled as Assertion (A) and the other is labelled as Reason (R): [NCERT Page 138 & 139]

**Assertion (A):** AIDS is caused by HIV virus.

**Reason (R):** HIV virus enters into macrophages where RNA genome of virus replicates to form viral DNA.

In the light of the above statements, choose the correct answer from the options given below:

- (1) Both A and R are true and R is the correct explanation of A.  
 (2) Both A and R are true but R is NOT the correct explanation of A.  
 (3) A is true but R is false.  
 (4) A is false but R is true.

**178.** Identify the statement that is correct.

[NCERT Page 131, 132]

- (1) When a Plasmodium infect RBC then haemozoin is formed inside the RBC as a natural cellular defense  
 (2) *Rhinoviruses* causes infection in lower respiratory tract but not in upper respiratory tract  
 (3) *Plasmodium* which causes malaria in humans is a tiny protozoan and it lives inside the body as a intercellular parasite  
 (4) *Haemophilus influenzae* causes infection in the alveoli of the lungs and it can be transmitted by sharing glasses and utensils with the infected person

**179.** Match List-I with List-II. [NCERT Page 142, 143]

<b>List-I</b>	<b>List-II</b>
A. Amphetamines	I. CNS depressant
B. Morphine	II. Depression
C. Crack	III. Effects cardiovascular system
D. Cannabinoid	IV. Interferes with dopamine

Choose the correct answer from the options given below:

- (1) A-II, B-I, C-IV, D-III    (2) A-III, B-I, C-IV, D-I  
 (3) A-I, B-IV, C-II, D-III    (4) A-IV, B-I, C-III, D-II

**180.** Colostrum secreted by mother during initial days of lactation contains antibody

[NCERT Page 136]

- (1) IgA                                      (2) IgE  
 (3) IgM                                      (4) IgG

